

## LED-EMG-10WCP

Version: A1

Page: 1/1

10W Constant Power - Direct Input - Emergency Driver

### 1 Dimensions

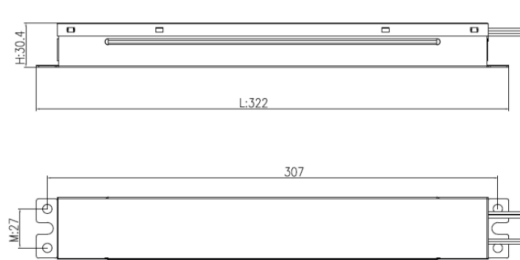

Dimension	Length
H	30.5mm (1.2 in)
W	43.2mm (1.7 in)
L	322.0mm (12.7 in)
M	27.0mm (1.1 in)

### 2 Electrical Characteristics

Input Information	Input Voltage	120-277V AC
	Frequency Range	50/60Hz
	Max. Power	10W
	Max.standby Power	1.8W
Output Information	Output Power	10W
	Emergency Time	90 min.@10W
	Output open protection	Yes
	Over power protection	Yes
Others Information	Compatibility	Internal / < 30W drivers
	Operation Temp.	0°C-50°C
	Battery Type	Lithium-Ion
	Battery Capacity	2200mAh 14.8V
	Charge Current	215mA
	Recharge Time Required	24 Hours MAX.
	UL Conditions of Acceptability	Battery temperature should not exceed 50°C
Warranty	5 Years Warranty	

### 3 Wiring Diagrams

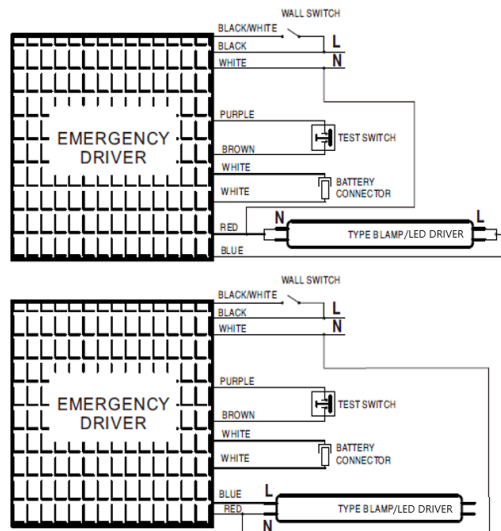

Wire Color	Wire Length
White	800mm (31 in)
Black-White	650mm (25 in)
Black	800mm (31 in)
Red	1200mm (48 in)
Blue	1200mm (48 in)
Purple	1200mm (48 in)
Brown	1200mm (48 in)
White	320mm (12in)
White	320mm (12in)

### 4 Certification

UL 924 and FCC